

Translation of the Original Operating Instructions

AutoMAB 350, 450



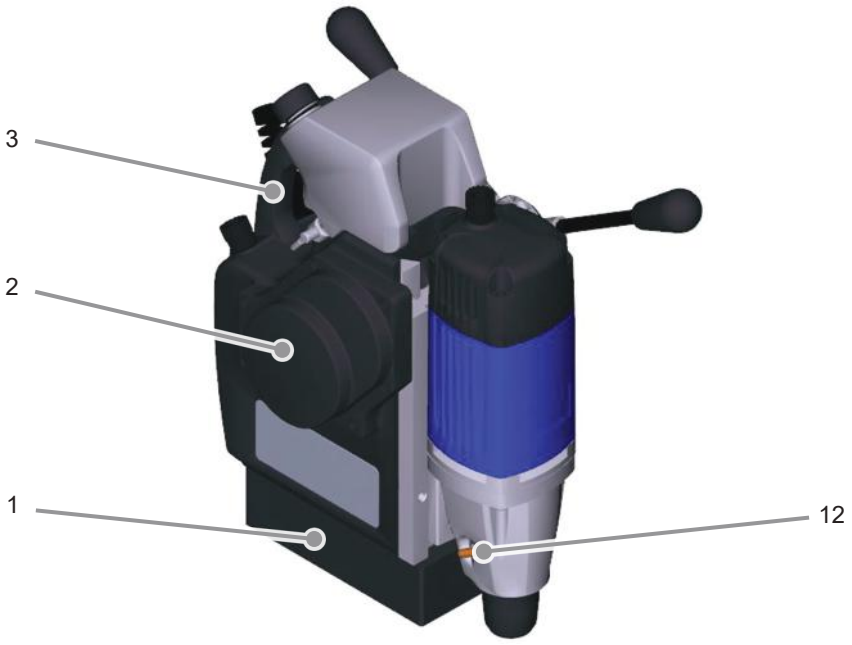

Table of contents

General instructions3
Safety5
Components / delivery contents9
Before using for the first time10
Preparation.11
Using.14
Eliminating blockages.17
Cleaning17
Maintenance.18
Storage18
Troubleshooting19
Technical data20
EC Declaration of Conformity21

Dear Customer,
 Before using the machine, please read the operating instructions contained in these operating instructions on startup, safety, intended use as well as cleaning and care. The links and illustrations in these instructions refer to the illustrations on the inside of the cover.
 Keep these operating instructions for later use and pass them onto the next owner of the machine.

General instructions

Copyright

This document is subject to copyright. Duplication or reprinting, even in part as well as reproduction of the illustrations, even if modified, is only permitted with written consent of the manufacturer.

Liability disclaimer

All technical information, data and instructions contained in these operating instructions for startup, operation and care correspond to the latest requirements at the time of printing.

The manufacturer assumes no liability for damage or injury resulting from failure to observe the operating instructions, use for other than the intended purpose, unprofessional repairs, unauthorised modifications or use of non-approved spare parts and accessories, tools and lubricants.

Instructions on disposal

 The packaging materials used can be recycled. When no longer required, dispose of the packing materials according to local environmental regulations.

 This product may not be disposed of in the European Union via the normal household refuse. Dispose of the device via communal collection points.

 The lubricant used can contain substances dangerous to the environment. Dispose of the lubricant according to local regulations. Observe the disposal instructions from the lubricant manufacturer.

Safety warning structure

The following warnings are used in these operating instructions:

DANGER

A warning of this category indicates an impending dangerous situation.

If the dangerous situation is not avoided, it may lead to serious injury or even death.

- ▶ Follow the instructions in this warning to avoid possible danger of serious injury or even death.

WARNING

A warning of this category indicates a potentially dangerous situation.

If the dangerous situation is not avoided, it may lead to serious injury or even death.

- ▶ Follow the instructions in this warning to avoid the danger of serious injury to persons.

ATTENTION

A warning of this category indicates potential danger to property.

If the situation is not avoided, it may lead to material damage.

- ▶ Follow the instructions in this warning to avoid material damage.

NOTE

- ▶ A note indicates additional information that simplifies the use of the machine.

Intended use

The machine is intended solely for drilling operations in magnetic and non-magnetic metals within the limits specified in the technical data.

Any use other than previously stated is considered as improper use.

WARNING

Danger due to improper use!

If not used for its intended purpose and/ or used in any other way, the machine may be or become a source of danger.

- ▶ Use the machine only for its intended purpose.
- ▶ Observe the procedures described in these operating instructions.

No claims of any kind will be accepted for damage resulting from use of the system for other than its intended purpose.

The risk must be borne solely by the user.

NOTE

- ▶ If used commercially, pay attention to compliance with the accident prevention and occupational safety regulations.

Safety

NOTE

When using electrical tools, the following fundamental precautions must be taken to protect against electric shock and the risk of injury and fire!

Fundamental safety instructions

- Do not use the machine in potentially flammable or explosive environments.
- Persons, who are unable to safely operate the machine due to their physical, mental or motor abilities, may only use the machine under the supervision or instruction of a person responsible.
- Persons with heart pacemakers or other medical implants must not use this machine.
- Children are not permitted to use the machine.
- Inspect the machine for visible signs of damage before use. Do not operate a damaged machine.
- Before beginning work, check the condition of the safety chain and the function of the switches on the machine.
- Repairs to the connecting cable may only be performed by a qualified electrician.
- Repairs to the machine may only be performed by an authorised specialist workshop or factory customer service. Unqualified repairs can lead to considerable danger for the user.
- Repairs to the machine during the guarantee period may only be performed by a customer service authorised by the manufacturer, otherwise the guarantee is invalid.
- Defective parts may only be replaced with original spare parts. Only these parts ensure that the safety requirements are met.
- Do not leave the machine unsupervised during operation.
- Store the machine in a dry, temperate location out of the reach of children.
- The machine may not be kept outside and be subject to humidity.
- Make sure that your work area is sufficiently lit (>300 Lux).
- Do not use low-power machines for heavy working.
- Pay attention to cleanliness at the workplace.
- Keep the machine clean, dry and free of oil and grease.
- Follow the instructions on lubricating and cooling the tool.

Danger from electric current!

DANGER

**Danger to life from electrical current!
Contact with live wires or components can lead to serious injury or even death!**

Observe the following safety precautions to avoid any danger from electric current:

- ▶ Do not open the housing of the machine. Risk of electric shock from touching live connections.
- ▶ Never immerse the machine or mains plug in water or other liquids.
- ▶ Only use extension cables or cable drums with a cable cross-section of at least 1.5 mm².
- ▶ Only use extension cables that are approved for the location of use.
- ▶ Check the condition of the extension cable regularly and replace if damaged.
- ▶ Avoid bodily contact with grounded parts (e.g., pipes, radiators, steel girders) to reduce the risk of electric shock in the event of a defect.
- ▶ When using the machine outside or in a humid environment, an RCD (residual circuit device) must be used.

Risk of injury!

WARNING

Improper handling of the machine increases the risk of injury!

Pay attention to the following safety instructions in order not to injure others or yourself:

- ▶ Operate the machine only with the protective equipment specified in these instructions (see section “**Personal protective equipment**”).
- ▶ **Do not** wear protective gloves when the machine is running. A glove can be caught by the drilling machine and torn off the hand. Risk of losing one or more fingers.
- ▶ Remove loose jewellery before beginning work. Wear a hair net if you have long hair.
- ▶ Always switch off the machine before changing tools, performing maintenance or cleaning. Wait until the machine has come to a complete standstill.
- ▶ Always remove the plug from the mains socket before changing tools, cleaning or performing maintenance work in order to avoid unintentional starting of the machine.
- ▶ Do not put your hand into the machine while it is in operation. Remove swarf only when the machine is at a standstill. Wear protective gloves when removing swarf.
- ▶ When working on scaffolding, the operator must be secured with a safety belt as the machine can oscillate dangerously in the event of interruption to the power supply.

⚠ WARNING

- ▶ Check for secure clamping of the electromagnets on the substrate before every use (see section *“Preparation”*).
- ▶ Secure the machine with the safety chain (D) supplied when working in an inclined or vertical position and during overhead work. The machine could fall down if the magnet is loosened or the power fails.
- ▶ Check that the tool is tightened securely before using (see section *“Inserting the tool”*).
- ▶ Do not allow the connecting cable to hang over edges (trip effect).

Preventing damage**ATTENTION****Potential damage to property if the machine is improperly used!**

Observe the following instructions to avoid damage to property:

- ▶ Before connecting the machine, compare the connection data (voltage and frequency) on the rating plate with those of your mains power supply. The data must correspond in order to avoid damage to the machine.
- ▶ Always use the handle to carry the machine and not the connecting cable.
- ▶ Do not pull the mains cable to remove the plug from the mains socket.
- ▶ Do not crush the connecting cable.
- ▶ Do not subject the connecting cable to heat or chemical liquids.
- ▶ Do not pull the connecting cable across sharp edges or hot surfaces.
- ▶ Lay the connecting cable in such a way that it cannot be caught and wound up in the rotating part of the machine.

Safety equipment

Restart protection

NOTE

- ▶ The machine stops automatically when the magnetic clamp is switched off, loses its adhesion, the overload protection is triggered or there is a power failure.

In order to prevent the machine from starting unexpectedly after switching the magnetic clamp on again or after reconnection following interruption to the power supply ("restart protection"), the machine must be switched on again using the Start/Stop switch.

Magnet indicator (Fig.1)

Der Magnetindikator (22) dient zur optischen Kontrolle der Magnethaltekraft.

- Magnet indicator (22) lights up **GREEN**: The magnetic clamping force satisfies the minimum requirements. Machining can be carried out.
- Magnet indicator (22) lights up **RED**: Insufficient magnetic clamping force. Do not operate the machine. This can be the case if the material is too thin, the surface is uneven or if coated with paint, scale or zinc.

NOTE

- ▶ If the clamping magnet loses adhesion during processing, the feed and drill motor is switched off. This is possible as the result of an unfavourable drill to feed speed ratio, so that the machine is squeezed off the substrate.

Overload protection (Fig.1)

The overload protection serves as optical control of the power consumption of the motor.

NOTE

- ▶ The machine stops automatically when the maximum power consumption is exceeded and the motor is overloaded.
- ▶ The clamping magnet remains switched on.



The power consumption is indicated by an LED bargraph display (24). The display increases from left to right.

LED	Colour	Power consumption
1-6	green	OK
7-9	yellow	Maximum (just before the switch-off point)
10	red	Overload (Drill motor and feed are switched off automatically after 5 seconds)

If the overload protection is triggered, the machine must be switched on again via the Start/Stop switch (Restart protection).



Symbols on the machine

The symbols on the machine have the following meaning:

Symbol	Meaning
	Electric shock hazard!
	Read the operating instructions before beginning work!
	Wear protective goggles and ear protection!

Personal protective equipment

Wear the following protective equipment at all times when operating the machine:

Symbol	Meaning
	Close-fitting work protection clothing with a low tear strength
	Goggles for protecting eyes against flying parts and liquids and ear protection in areas with noise emission >80 dB(A)
	Safety shoes for protecting feet against falling objects.

Also wear the following protective equipment during special work:

Symbol	Meaning
	Helmet for protecting your head against falling objects
	Wear a harness where there is a danger of falling.
	Gloves for protection against injuries

Components / delivery contents

Machine overview

1	Magnetic foot
2	Feed motor
3	Handle
4	Tool mount AutoMAB 350 - Weldon 19 mm (3/4) AutoMAB 450 - MK2 industrial holder with manual clamping
5	Gearbox: AutoMAB 350 - single-stage AutoMAB 450 - two-stage with selector switch
6	Engine drive
7	Coolant/lubricant tank
8	Coolant/lubricant tank filling hole with cover
9	Hand lever
10	Operating panel
11	Machine slide and guide
12	Connection for internal lubrication

Operating panel

(see fig. 1)	
21	Magnet ON/OFF switch
22	"Magnet Power" indicator
23	Motor start/stop switch
24	"Motor Power" bargraph display

Operating lever

(see fig. 2)	
9	Hand lever
Pos. 1	Automatic feed switched on
Pos. 2	Automatic feed switched off Manual feed

Scope of supply

	AutoMAB 350/450 core drilling machine
A	Safety chain
B	ZAK 075 ejector pin
C	ZAK 100 ejector pin
D	Hexagonal offset screwdriver: AutoMAB 350 - Size SW4 AutoMAB 450 - Size SW5
E	Weldon MK2/19 mm industrial holder (AutoMAB 450 - ZIA 219 KN)
	Transport case (not illustrated)
	Operating instructions/guarantee card (not illustrated)

Before using for the first time

Transport inspection

As standard, the machine is supplied with the components indicated in the **“Scope of supply”** section.

NOTE

- Check for visible signs of damage or missing items on delivery. Report an incomplete or damaged delivery to your dealer/supplier immediately.

Preparation

This section contains important instructions on the required preparation before beginning any work.

Additional safety measures for certain work

Additional safety precautions must be taken for the following operations with the machine:

Non-horizontal work position

WARNING

Risk of injury from a falling machine.

When working in inclined or vertical position and during overhead work, the machine must be secured to prevent it from falling using the safety chain (A) supplied.

- ▶ Check the safety chain for proper function before every use. A damaged safety chain must not be used. Replace a damaged safety chain immediately.
- ▶ Attach the safety chain in such a way that the machine moves away from the operator in the event of slipping.
- ▶ Lay the safety chain as tightly as possible around the handle of the machine.
- ▶ Check the secure fitting of the safety chain and lock before starting work.
- ▶ Use the protective equipment stipulated in the section **“Personal protective equipment”**.

Work on scaffolding

WARNING

Risk of falling from sudden oscillating movements of the machine.

When working on scaffolding, the machine can make a sudden oscillating movement on starting or in the event of interruption to the power supply.

- ▶ Secure the machine with the safety chain (A) supplied.
- ▶ Wear a safety harness to protect yourself against falling.

Check the condition of the substrate

The magnetic holding force is dependent on the condition of the substrate. The clamping force is significantly reduced by paint, zinc and scale coatings and rust.

The substrate must satisfy the following conditions in order to achieve sufficient magnetic holding force:

- The substrate must be magnetic.
- The clamping surface and the magnetic foot (1) must be clean and grease-free.
- The clamping surface must be completely smooth and level.

NOTE

- ▶ Clean the substrate and the magnetic foot (1) of the machine before use.
- ▶ Remove any unevenness and loose rust from the substrate.

The best clamping effect is obtained on low-carbon steel substrate with a thickness of at least 20 mm.

Steel with low thickness

When drilling into low thickness steel, an additional steel plate (minimum dimensions 100 x 200 x 20 mm) must be placed under the workpiece. Secure the steel plate to prevent it from falling.

NF metals or workpieces with an uneven surface

A special holding device must be used when drilling into NF metals or into workpieces with an uneven surface.

NOTE

- ▶ BDS offers a range of accessories with special holding and clamping devices for tubes and non-magnetic materials.

Inserting the tool

⚠ WARNING

Risk of injury!

- ▶ Do not use damaged, contaminated or worn tools.
- ▶ Change tools only when the machine is switched off and at a standstill. Pull the plug out of the mains socket.
- ▶ After inserting, check that the tool is engaged securely.
- ▶ Only use tools, adapter and accessories that match the machine.

AutoMAB 350**Inserting the core drill (Fig.3)****Inserting the tool**

- ◆ Before mounting, clean the Weldon shank of the core drill and tool mount of the machine.
- ◆ Check the cable connection for grease.
- ◆ Untighten both hexagonal socket screws in the tool mount with the Allen wrench (D) supplied.
- ◆ Insert the core drill into the tool mount.

NOTE

- ▶ Insert the appropriate ejector pin (B,C) before inserting a core drill.

- ◆ Tighten both hexagonal socket screws in the tool mount with the Allen wrench (D) supplied.

Removing the tool

- ◆ Untighten both hexagonal socket screws in the tool mount with the Allen wrench (D) supplied and remove the tool from below.

AutoMAB 450**Insert the core drill into the industrial holder (Fig. 4)**

- ◆ Push the industrial holder (4) into the spindle taper of the machine.
- ◆ Before inserting, clean the Weldon shank of the tool and the tool holder.
- ◆ Check the cable connection for grease.
- ◆ Unscrew both hexagonal socket screws in the tool mount using the hexagonal offset screwdriver (D) supplied.
- ◆ Insert the core drill into the tool mount.

NOTE

- ▶ Please only use an industrial holder with manual clamping for this machine (in the scope of supply)!
- ▶ Insert the appropriate ejector pin (B, C) before inserting the core drill.
- ◆ Tighten both hexagonal socket screws in the tool mount using the hexagonal offset screwdriver (D) supplied.

Removing the tool

- ◆ Unscrew both hexagonal socket screws in the tool mount using the hexagonal offset screwdriver (D) supplied and remove the core drill from below.

Using

Select the speed range (AutoMAB 450 only)

ATTENTION

- ▶ Switch the gear stages only with the machine at standstill.

NOTE

- ▶ Select the speed range according to the material and drilling diameter.

Select the gear stage

The machine has a gearbox with two mechanical gear stages. The rotation speeds of the gear stages are specified in the technical data.

- ◆ To select the desired gear stage, set selector lever on the gearbox (2) to stage 1 or 2 with the machine switched off.

Activating/deactivating the magnetic clamp

Activating the magnetic clamp

ATTENTION

- ▶ To prevent the magnet from overheating, switch on the magnetic clamp only when the machine is standing on a magnetic substrate.
- ◆ Turn on the switch (21). The indicator lamp in the switch (21) lights up.
- ◆ Check the magnet holding force with the magnet indicator ("MAGNET POWER" (22) indicator light).

"MAGNET POWER" indicator light	Magnetic holding force condition
GREEN	Sufficient magnetic holding force
RED	Insufficient magnetic holding force

ATTENTION

- ▶ The maximum magnetic holding force is only available after switching on the motor.

Deactivating the magnetic clamp

- ◆ Hold the handle tightly (3) to stop the machine from slipping.
- ◆ Turn the switch (21) off. The indicator lamp in the switch (21) extinguishes.

Switching automatic feed on/off

The automatic feed can be switched on and off at any time.

Switching on automatic feed

- ◆ Move the hand lever (9) in the direction of the machine housing to position 1 (see fig.2).

NOTE

- ▶ The automatic feed stops when reaching the lower end position of the machine slide and moves back to the upper slide position automatically.
- ▶ The automatic feed can be interrupted at any time by pulling back one of the three hand levers (9) (see also **"Switch off the automatic feed"**).
- ▶ The motor can only be switched on when the indicator lamp lights up **GREEN**. When **RED**, the feed and the drill motor are switched off automatically.

Switch off the automatic feed

- ◆ Move the hand lever (9) away from the machine housing to position 2 (see fig.2).

NOTE

- ▶ If the clamping magnet loses adhesion during processing, the feed and drill motor is switched off. This is possible as the result of an unfavourable drill to feed speed ratio, so that the machine is squeezed off the substrate.

Switching the machine ON/OFF

Switching on the machine

- ◆ Switch on the machine with the start/stop switch (23).
The indicator lamp in the switch (23) lights up.

NOTE

- ▶ The machine can only be switched on when the magnetic clamp has been switched on and the indicator lamp lights up **GREEN**.
- ▶ Allow a severely overheated machine to run on at idle speed for approx. 2 minutes.
- ▶ The machine switches off automatically in the event of a power failure, overload or if the magnetic clamp is switched off.

Switching off the machine

- ◆ Switch off the machine with the start/stop switch (23).
The indicator lamp in the switch (23) extinguishes.

Drilling with the machine

Drilling with core drills

When drilling with core drills, proceed as follows:

- ◆ Insert the corresponding ejector pin into the core drill.
- ◆ Insert the core drill into the tool mount (see section ***“Inserting the tool”***).
- ◆ Place the machine at the location of use, align it.
- ◆ Switch on the clamping magnet and check the magnetic holding force (see section ***“Activating/deactivating the magnetic clamp”***).
- ◆ Switch on the machine (see section ***“Switching the machine ON/OFF”***).
- ◆ Direct the drill to the material with the handle (9).

NOTE

- ▶ As an alternative to guiding the drill with the hand lever, the drilling procedure can also be performed automatically. Switch on the automatic feed for this purpose (see section ***“Switching automatic feed on/off”***).

After successful drilling:

- ◆ Move the hand lever to position 2 (see fig. 2).
- ◆ Move the machine slide to the upper position with the hand lever.
- ◆ Stop the machine.

NOTE

Observe the following instructions when drilling with core drills:

- ▶ Drilling with core drills does not require great force. The drilling process is not accelerated by higher pressure. The drill wears faster and the machine can be overloaded.
- ▶ Use the high-performance BDS 5000 cutting oil in the cooling lubricant system of the machine.
- ▶ The cooling lubricant system cannot be used when working overhead. In this case, use the high-performance ZHS 400 grease spray. Spray the drill on the inside and outside before drilling. In the case of larger drill depths, repeat this procedure.
- ▶ Make sure that swarf is removed regularly. With larger drilling depths, break up the swarf.

Eliminating blockages**⚠ WARNING**

Danger of cut injuries from broken tool parts or swarf.

- ▶ Put protective gloves on before starting work.

Blockages caused by a broken tool:

- ◆ Switch off the machine. Remove plug from the mains socket.
- ◆ Use the handle to move the machine slide to the upper position.
- ◆ Replace defective tool. Remove swarf.

Other blockages:

- ◆ Switch the machine off using the motor switch. Leave the magnetic clamp switched on.
- ◆ Use the handle to move the machine slide to the upper position.
- ◆ Remove swarf and check tool.

Cleaning**⚠ WARNING**

- ▶ Switch off the machine and pull the plug out of the mains socket before starting maintenance and cleaning.
- ▶ When using compressed air for cleaning, wear protective goggles and gloves and protect other persons in the working area.

ATTENTION

- ▶ Never immerse the machine in water or other liquids.

After each use

- ◆ Remove the inserted tool.
- ◆ Remove swarf and coolant residues.
- ◆ Clean the tool and the tool holder on the machine.
- ◆ Clean the guide of the machine slide.
- ◆ Put the machine and accessories into the transport case.

Maintenance

WARNING

Danger caused by unqualified repairs!

Unqualified repairs can lead to considerable danger for the user and cause damage to the machine.

- ▶ Repairs to electrical appliances may only be carried out by the works customer service or by specialists trained by the manufacturer.

Adjusting the machine slide guide

If the machine slide guide (11) exhibits too much clearance, it must be adjusted. To do this, proceed as follows:

- ◆ Loosen the clamping bolts.
- ◆ Tighten the adjusting screws evenly.
- ◆ Tighten the clamping bolts again.

Replacing the carbon brushes

Replacement of the carbon brushes may only be carried out by BDS or by an authorised specialist workshop. Unauthorised repairs will invalidate the guarantee.

Customer service/service

Should you have any questions on customer service/service, please contact BDS. We will be happy to give you the address of your nearest service partner.

Storage

If you do not intend to use the machine for a longer period of time, clean it as described in the section "**Cleaning**". Store the machine and all its accessories in the transport case at a dry, clean and frost-free location.

Troubleshooting

Error	Possible cause	Remedy
The motor does not start after pressing the ON/OFF switch or stops during operation.	Plug not inserted into socket.	Insert plug.
	Circuit breaker switched off.	Switch on circuit breaker.
	The magnetic clamp is not switched on.	Switch on the magnetic clamp.
	The internal overload protection has switched off the motor due to too high power consumption.	Check tool, machine and workpiece. Operate the machine within the limits of the technical data.
Contact customer service.		
The circuit breaker in the power distributor trips.	Too many appliances connected to the same power circuit.	Reduce the number of appliances on the power circuit.
	The machine is defective.	Contact customer service.
The automatic feed does not work.	The automatic feed is not switched on.	Switch on the automatic feed.
The magnetic clamp does not function.	Magnet not switched on.	Switch on magnet.
	The surface is not magnetic.	Use a suitable base.
The lubrication system does not function.	No lubricant available.	Top up the lubricant.
	Lubricant tap closed.	Open the lubricant tap.
	Connecting nipple clogged.	Clean the tank and nipple.

NOTE

- ▶ If you cannot resolve the problem with the steps described above, please contact customer service.

Technical data

Model	AutoMAB 350	AutoMAB 450	
Dimensions (L x W x H)	271x196x310/460	280 x 163 x 430/590	mm
Magnetic foot (L x W)	84 x 168	84 x 168	mm
Approx. net weight.	15	16	kg
Operating voltage (see type plate)	230 V / 50-60 Hz or 110-125 / 50-60 Hz		
Power consumption	1050	1150	W
Noise emission	87	87	db(A)
Vibration	0.81	0.81	m/s ²
Stroke	150	160	mm
Core drill, short Ø	12 - 35	45	mm
Core drill, long Ø	12 - 35	45	mm
Overload protection (motor power consumption)	YES	YES	
Permanent internal lubrication	YES	YES	
Automatic feed	YES	YES	
Speed:			
Level 1	n0 = 750 n = 460	n0 = 400 n = 250	rpm
Level 2	-	n0 = 730 n = 450	rpm
Core drill assembly	Weldon 19 mm (3/4")	MK2/19 mm industrial holder (3/4")	
Connecting cable length	4	4	m
Protection class	I	I	
Protection type	IP20	IP20	

EC Declaration of Conformity

in accordance with Machine Directive 2006/42/EC, appendix II 1A	
Name/address of the manufacturer:	BDS Maschinen GmbH Martinstraße 108 D-41063 Mönchengladbach
We hereby declare that the product:	
Model:	Magnetic core drilling machine
Model	AutoMAB 350, 450
conforms to the following relevant regulations: <ul style="list-style-type: none"> ■ EC Directive 2006/42/EC on machinery 	
The following harmonised standards were applied in whole or in part: <ul style="list-style-type: none"> ● DIN EN ISO 12100:2011-03 ● DIN EN 61029-1/A11:2011-11 	
Authorised person for compiling the technical documentation:	BDS Maschinen GmbH
Full technical documentation is available. The operating instructions associated with the product is available.	
It is required that the product is only operated as intended. Information on operating as intended can be obtained from the technical documentation.	
Mönchengladbach, 1st. November, 2016	 Wolfgang Schroeder, Technical Director <hr/> (Legally binding signature of the issuer)

Fig. 1

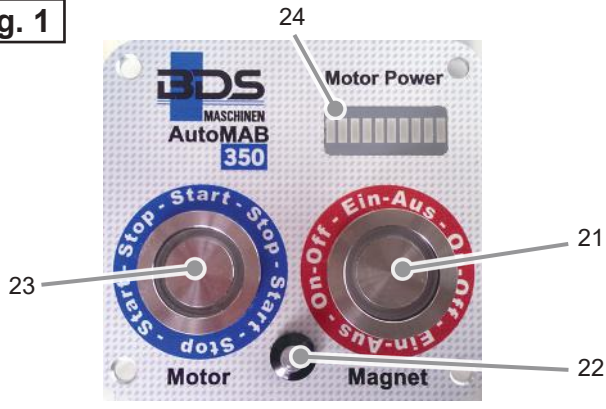

Fig. 3



Fig. 2

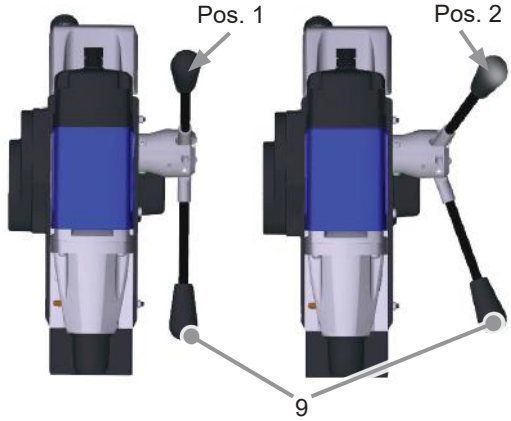

Fig. 4



BDS Maschinen GmbH

Martinstraße 108
D-41063 Mönchengladbach

Fon: +49 (0) 2161 / 3546-0

Fax: +49 (0) 2161 / 3546-90

Internet: www.bds-maschinen.de

E-mail: info@bds-maschinen.de
